

Forklifts of Michigan
 www.forkliftsmi.com
 (616) 455-2376



Reliability.
 It's the defining trait of our company and our forklifts.



Platinum II® Nomad Series



Rear LED Combination Lights
 Package includes a reflector, turn signals, brake and back-up lights. Design provides high visibility and vibration resistance for long life and low service costs. Choose vertical or horizontal mounting (shown).



Travel Speed Control
 Select maximum travel speed settings based on operator skill level or application.



Security Key Switch
 Choose this option to prevent operator tampering with pre-selected settings.



UniCarriers' roots extend back over 100 years, and over that time, strong, reliable performance has always been the hallmark of our organization, our people and our equipment.

Today, our unrivaled reliability continues to provide UniCarriers' customers with a competitive edge. And together, we move the merchandise that moves world commerce with greater efficiency, economy and reliability.

When it comes to providing forklifts that make a difference for our customers and theirs...

We Never Quit.



Spinner Knob
 Provides operators with easier control behind the wheel.



Air Filled Pneumatic Tires
 Delivers an even smoother ride over cracks in pavement or dock plates.



Auto-Tilt Leveling System
 Press the button on the hydraulic control lever to tilt the forks forward to a horizontal position. Used for easier load placement and retrieval operations.



Radiator Screen
 Minimizes debris entering radiator, resulting in more efficient engine cooling.



Diffusion Exhaust
 Disperses exhaust through the counter-weight opening — prevents debris kick-up and external heat damage.



OptiView® Mast
 Provides a wider sightline for improved load handling and operator visibility.



Engine Powered Forklifts

LP & Dual Fuel
3,000 / 3,500 / 5,000 lbs. Capacities | Compact Pneumatic Tire



SB-NOMAD 07-2015 Printed in U.S.A.

UniCarriers® is a registered trademark of UniCarriers Corporation. UniCarriers Americas Corporation reserves the right to make product changes relating to colors, equipment, specifications or available options without notice. For more information, contact your UniCarriers representative.



Nomad Series Applications

The Nomad is the industry's only indoor-outdoor hybrid forklift — bringing new levels of efficiency and economy to operations such as:

- Rental Operations
- Unique or Limited Space Applications
- Seasonal Retail Sales
- Nurseries/Garden Centers
- Home Improvement Stores



Look for these symbols for features available only on UniCarriers forklifts or that provide a proven performance advantage as compared to competitive trucks.



NEVER QUIT.

It defines our forklifts and the company that builds them.

Over the course of a century, the company known as UniCarriers took shape. As we grew and evolved into a US manufacturer with a global reach in nearly 100 countries worldwide, much has changed, but one thing hasn't: our mission. UniCarriers is committed to providing you with the ultimate in reliability, performance, and value.

And that commitment can be seen in the Nomad Series. For versatility, performance and bottom line value, there's nothing like the Nomad Series forklift. No other forklift is designed to move loads seamlessly from indoors to outdoors. Only the Nomad combines a compact, highly maneuverable chassis to negotiate narrow aisles inside with a heavier frame and wider stance for rugged outdoor performance. Plus, it's backed by the best standard, limited warranty in the business.



Versatility & Value

Nomad: the one forklift that delivers amazing performance inside and out



Up Your UpTime

Discover reliability features that cut downtime and keep your business up and running



Comfort Zone

Your drivers and your entire operation will benefit from our comfort & productivity features



Power & Performance

Our K21 engine is designed and built for maximum economy, efficiency and productivity



Sweet Savings

The Nomad is designed to deliver you a low cost of ownership year after year after year



Play It Safe

Safety is everybody's business, and the Nomad is all business when it comes to safety



Control Freak

With the Nomad, you're in complete control when it comes to managing costs and productivity



Make It Yours

Already well appointed, the Nomad can be customized to meet your specific needs



To learn more, and a find a dealer near you, visit UniCarriersAmericas.com

Versatility and Value



UNI CARRIERS.
[FORKLIFT]

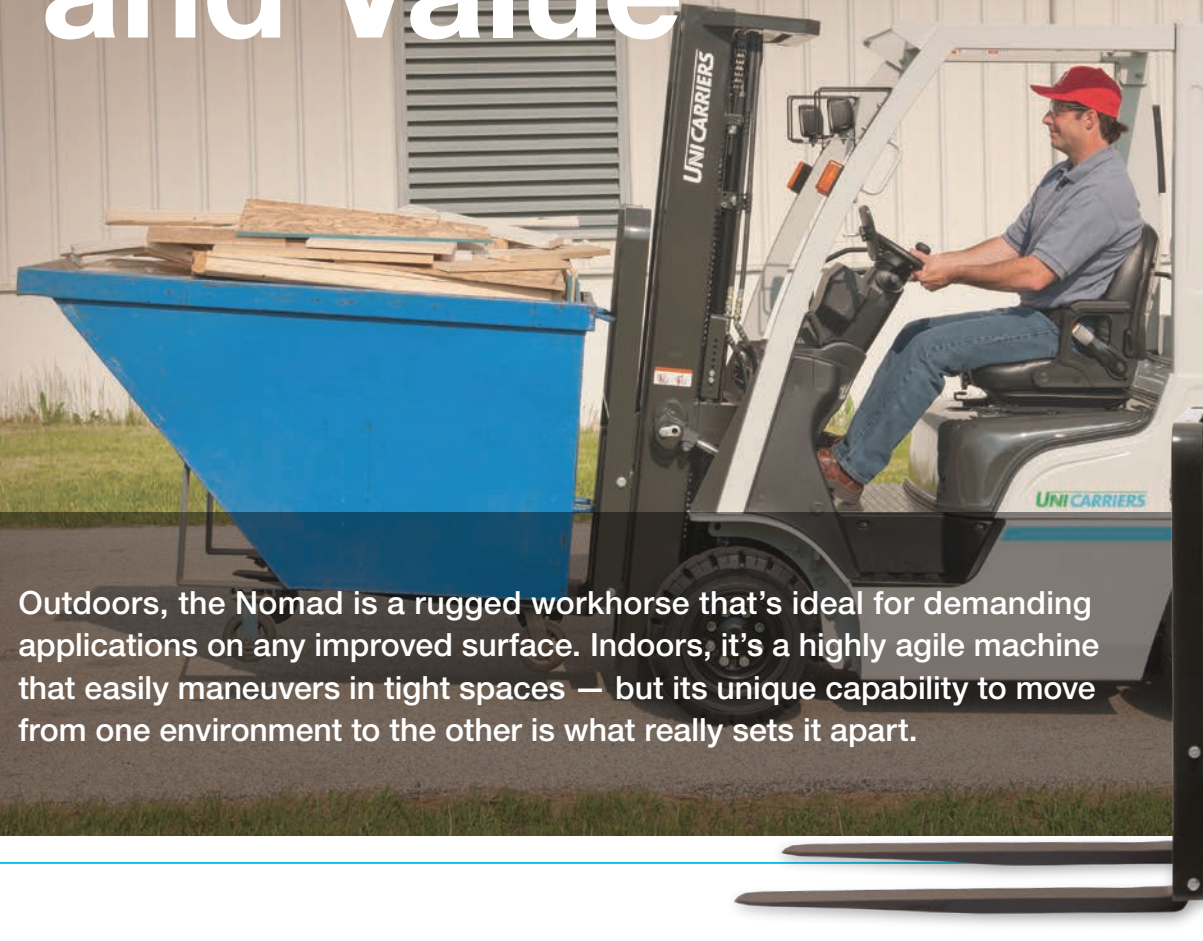

Outdoors, the Nomad is a rugged workhorse that's ideal for demanding applications on any improved surface. Indoors, it's a highly agile machine that easily maneuvers in tight spaces — but its unique capability to move from one environment to the other is what really sets it apart.



The Nomad puts an end to the waste of time, space and trouble of setting up staging areas and transferring loads. It is truly a hybrid that combines the best of both cushioned tire and pneumatic tire models to reduce cycle times, increase efficiency and maximize the productivity of your operation.



Dual-Fuel Flexibility

The Dual-Fuel model's K21 engine is powered by gas or LP — for high power and low emissions indoors and out.

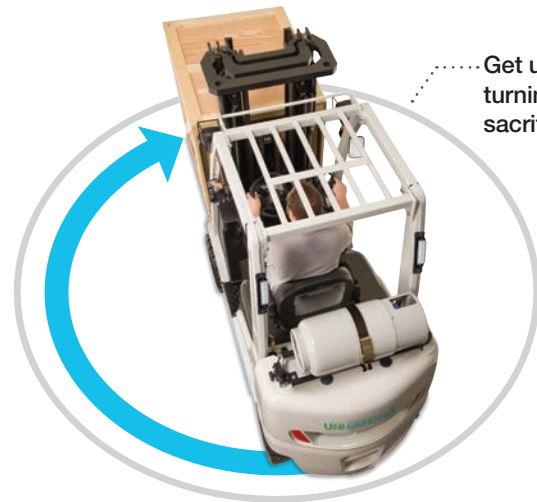

Get up to 8% tighter turning radius without sacrificing capacity.*

72.6-87.5
INCHES

Outmaneuvers the Competition

A shorter frame combined with a wider, shorter wheelbase creates a tighter turning radius and the precise maneuverability of a cushion tire truck, without sacrificing capacity.



Solid Performance Advantages

The solid pneumatic tires enable the Nomad to work on a variety of surfaces — from the factory floor to the loading dock and work yard. The Nomad also maintains higher capacity retention than similarly sized pneumatic forklifts while it virtually eliminates flat tires.

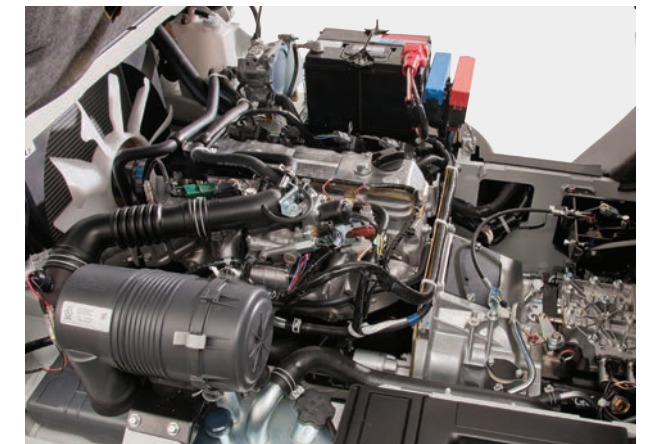

Breathe Easier

Whether you choose our LP or dual-fuel engine, our legendary K21 provides the ultimate combination of power, torque and low emissions.

Up Your UpTime

Trained technicians can **program service interval alerts** for each unit in operation through the meter panel. Drivers are notified when scheduled maintenance is required.



When it comes to keeping your operation up and running, the Nomad Series offers you significant advantages, beginning with a reliable cooling design, service reminders and longer maintenance intervals. Throughout the Nomad you'll find innovative and proven protection and warning systems to help you maximize uptime, while minimizing cost.

Longer Preventative Maintenance Intervals

With the Nomad Series, most major service intervals are only required every 500-600 hours, reducing labor and lowering your operating costs.



The Nomad's display includes **standard warnings like an air cleaner light (if clogging occurs) and low coolant level.** You'll find common sense features like these as standard equipment on our forklifts – but not on our competitors'.



A standard **parking brake transmission interlock** keeps the forklift in neutral and prevents the operator from driving while the parking brake is engaged to protect the brakes and transmission and reduce premature brake wear.



Inhibit operators from shifting at high speeds with our **SmoothShift** system. This option limits transmission shock and excessive wear — and extends service life too.



Easy LP Tank Changes

With our simplified LP replacement system, an optional bracket swings out 90°, then pulls down to a manageable height, for faster, easier tank replacement. *Not available on all models.*



Keep your starter and battery healthy with a **starter interlock.** This optional equipment **protects the forklift's starting system** by restricting repeated attempts to start the engine when the LP system is out of fuel.



Sensor monitors radiator coolant temperature

Sensor monitors transmission oil temperature

Hot Air

Cool Air

Cool Air

UNI CARRIERS ADVANTAGE

Bottom Bypass Design

From water outlet (Bottom bypass)

To water pump

From intake manifold (Bypass)

From radiator

Defend Against Overheating

Our reliable cooling system includes an electronic engine protection and warning system that **monitors radiator fluid and transmission oil temperatures at all times.** This system also contains a field-proven bottom bypass design with thermostat to **prevent hot spots and prolong engine life.** And its large 10-blade fan and aluminum radiator produce effective cross-flow cooling.

Reduce Downtime through Self-Diagnostics

Integrated **on-board diagnostics** provides immediate truck status. Standard equipment on the Nomad Series, this intuitive dialogue display, combined with accessible service history, **reduces troubleshooting time**, so the unit is back in operation faster. Everything is done through its smart LCD panel. No handset device is needed.





Comfort Zone

Driving a forklift can be both physically and mentally fatiguing, which can impact the health and well-being of your operators, the safety of your facility and the productivity of your operations. That's why UniCarriers incorporates proven, ergonomic designs throughout our forklifts to optimize the comfort, visibility and performance of your operators.



Our Seat Supports Your Driver and Your Productivity

The lumbar support and weight adjustments create customized comfort for the operator, while a non-cinching seatbelt allows a wider range of movement. The full suspension design absorbs shocks for a smoother, more comfortable ride — and it's all standard on Nomad Series forklifts.

Lumbar support adjustment

Weight adjustment

Seat and backrest cushions can be individually replaced for enhanced savings.

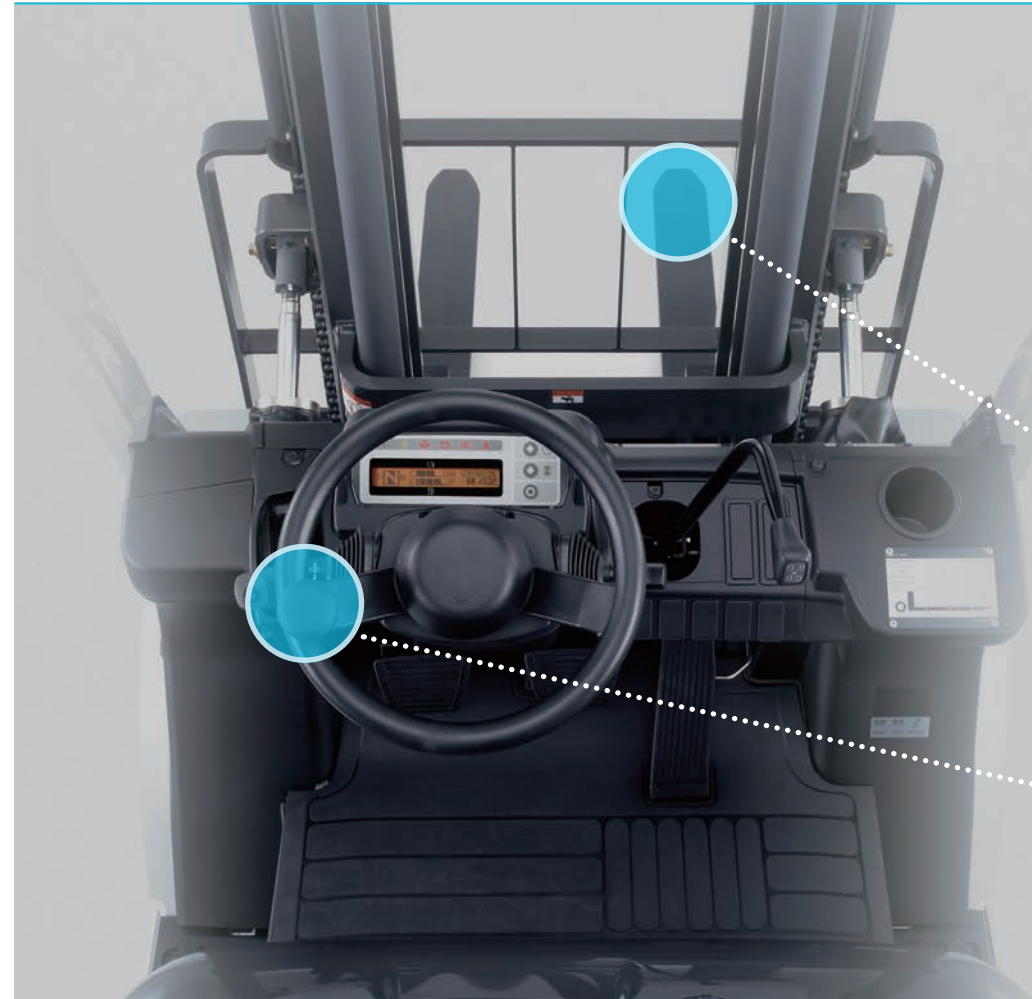

Big Time Comfort

The Nomad may be compact on the outside, but it provides plenty of foot, leg and head room inside.

Better Fork Tip Visibility

Controls are ergonomically placed across a low profile cowl, making visibility while picking up loads easier for a variety of operator heights.

Add a Spinner Knob for Easier Handling

Operators love this optional feature because it gives them even easier control behind the wheel.



Superior Visibility

A standard high-visibility carriage and your choice of an OptiView®, triple stage or wide-view mast — together these features produce clear sightlines for both loading and moving.



Convenience at Your Fingertips

Standard automotive-style controls are located on either side of the steering column for accessibility and intuitive operation.



Improved Control and Security

Maneuverability during reverse driving is easier with an optional secure assist grip. And it helps keep the operator's hand inside the compartment where it belongs. A horn button is included.



Power & Performance



The reliability, power and performance of the legendary K21 engine are at the heart of the Nomad — and only UniCarriers offers a transmission designed and paired to the K21. The result is an ideally optimized powertrain that delivers more torque at lower RPMs...exceptional efficiency...greater fuel economy... ultra low exhaust emissions — and a lifetime of enduring value.



More Power, More Efficiently

Advanced engine technology makes it possible for our K21 engine to deliver **greater torque at lower RPMs**. This is achieved due to a combination of factors, including **direct ignition coils connected to each cylinder**, a centrally positioned spark plug on the combustion chamber as well as electronic monitoring and control systems. Nomad models also include an atmospheric sensor that delivers enhanced performance in high altitudes.

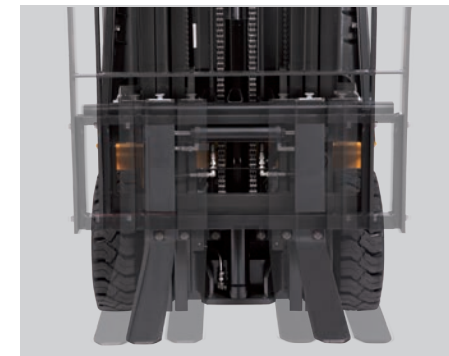

Smooth Operators

With our optional integral side shifter, your operator requires fewer moves to store and retrieve loads — this time-saving feature also minimizes capacity loss versus hang-on designs.



Built for Rugged Dependability

Solid steer axles and thick steel front fenders provide protection against harsh work environments.



Amazing Agility

A small steering wheel, compact frame size and intuitive controls add to the Nomad's extraordinary ability to maneuver within confined areas of the warehouse.

The Nomad's standard Power setting allows you to achieve maximum performance — and an annual productivity increase of up to 2500 cycles per truck.

Study findings are based on a 1200-hour usage

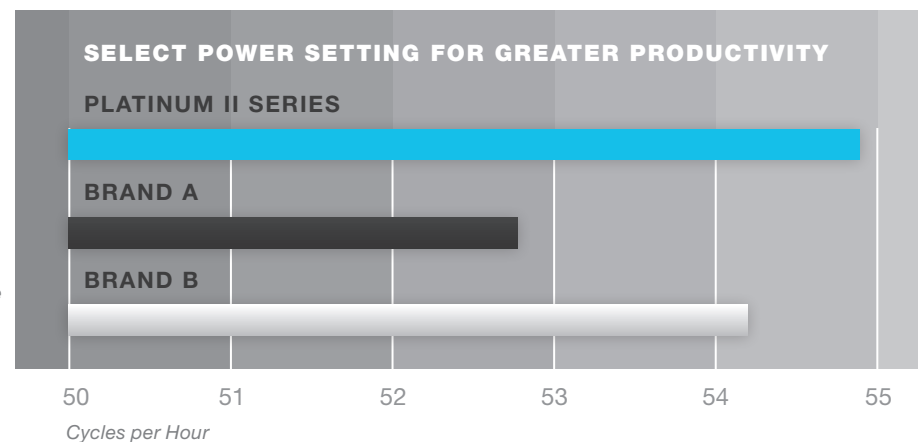

Switch to the Nomad's optional Economy mode to get greater fuel efficiency. Independent testing has shown our K21 engines use nearly 11% less fuel compared to competitive models under unloaded conditions.*

** Results based on 5000 lb. capacity LP cushion tire models in Economy mode.*

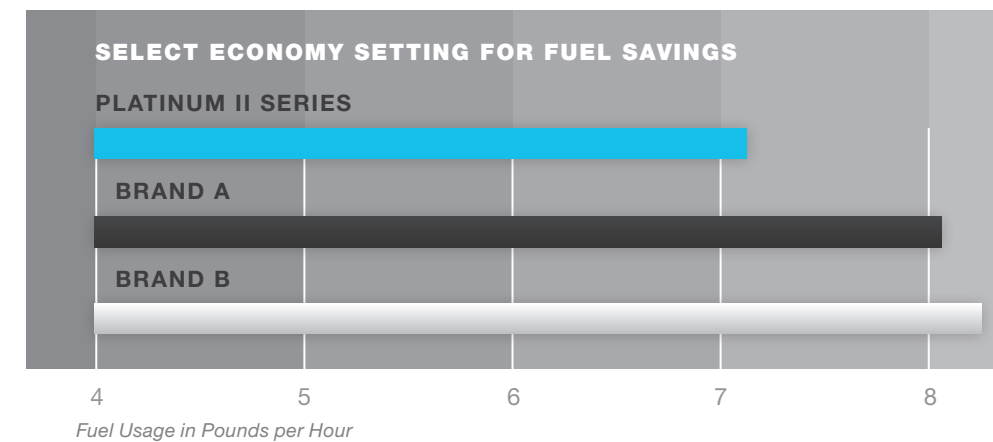

Sweet Savings



Extra Protection Without Extra Expense



In the event of excessive heat or loss in engine oil pressure, our **Powertrain Protection System** reduces engine RPM, for longer engine and drivetrain life. This great feature is standard on Platinum II Nomad Series models, versus competitive forklifts requiring a costly add-on.

Reduce Tire Wear & Save Fuel



Our power/economy controlled acceleration feature restricts the acceleration rate to **maximize fuel economy and minimize tire spin**. Gradual acceleration is also **useful when moving fragile loads or operating in confined areas**. Three design choices for this option offer increasingly more **security against tampering**: toggle switch, key switch or set internal parameters to keep this feature activated.

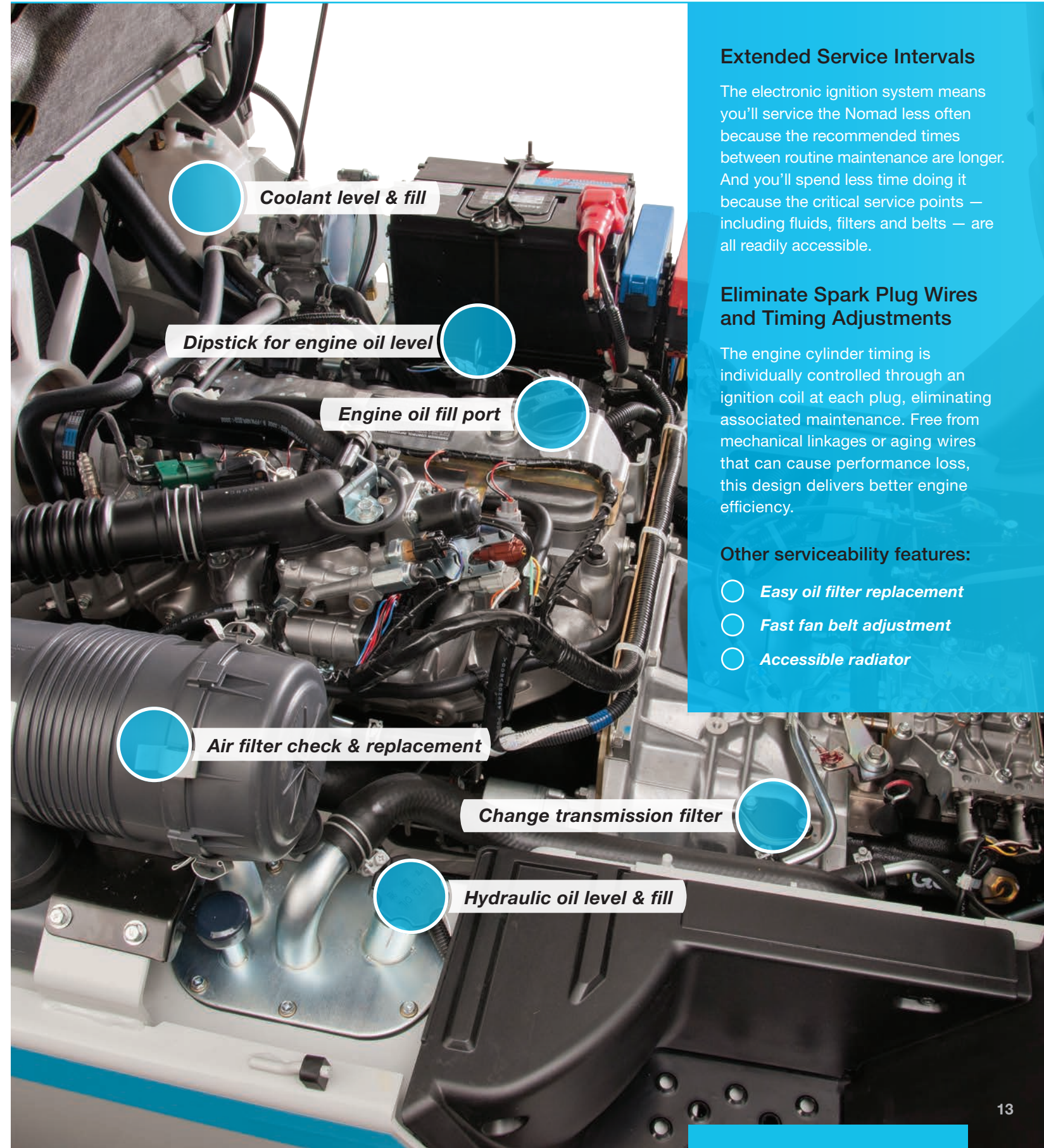

Coolant level & fill

Dipstick for engine oil level

Engine oil fill port

Air filter check & replacement

Change transmission filter

Hydraulic oil level & fill

Extended Service Intervals

The electronic ignition system means you'll service the Nomad less often because the recommended times between routine maintenance are longer. And you'll spend less time doing it because the critical service points — including fluids, filters and belts — are all readily accessible.

Eliminate Spark Plug Wires and Timing Adjustments

The engine cylinder timing is individually controlled through an ignition coil at each plug, eliminating associated maintenance. Free from mechanical linkages or aging wires that can cause performance loss, this design delivers better engine efficiency.

Other serviceability features:

- Easy oil filter replacement
- Fast fan belt adjustment
- Accessible radiator



Long Life LEDs

Everything about the Nomad is designed for longer life and greater savings, including the standard LED headlights that deliver greater visibility while being more economical and cost-effective over the life of the machine.

Repositionable Headlights



Save More, Waste Less



With the Nomad's **standard LPM_{ax} System** nearly every drop of liquid LP is used thanks to its reliable and timely low fuel warning, **reducing early tank replacement and saving you money**. An average 8-minute* warning means the operator can maximize productivity — instead of lugging an empty tank to the refill station.



Our Overhead Guard Reduces Your Overhead

Beyond ample headroom, the five-piece overhead guard takes **75% less time to make needed replacements** versus competitors' single-piece, welded-on guards. That cuts downtime and costs.

*Based on typical traveling operation in unloaded condition. Time interval varies depending upon individual application and usage.



Play It Safe

As a leader in clean air engines for nearly a decade, our products have benefited from the knowledge gained through our automotive heritage. Our K21 industrial engine incorporates an electronic engine control system, using a closed loop design to produce high combustion efficiency with lower and cleaner emission levels. We've also included several security systems as standard, and more options to meet your particular needs.



For Even Greater Security

Several options are available for added protection:

- **Seatbelt Interlocks** include a variety of choices for restricting forklift operations if the seatbelt is not latched.
- **Fire Extinguisher** mounted to the overhead guard pillar, for quick and easy access.
- **Orange Seatbelt** is highly visible, making seatbelt usage easier to enforce.
- **LP Safety Rating** is UL approved.

Operator Presence System



This comprehensive system includes a **seat-actuated power interrupt with mast-lock**, automatically preventing lift and tilt operations if the operator leaves the seat. The **return-to-neutral** feature minimizes forklift movement if the operator leaves the truck while still in gear. Other audible and visual warnings come standard, including **parking brake warning** and **seatbelt alarm**.



A rubber damper provides enhanced stability and easier handling

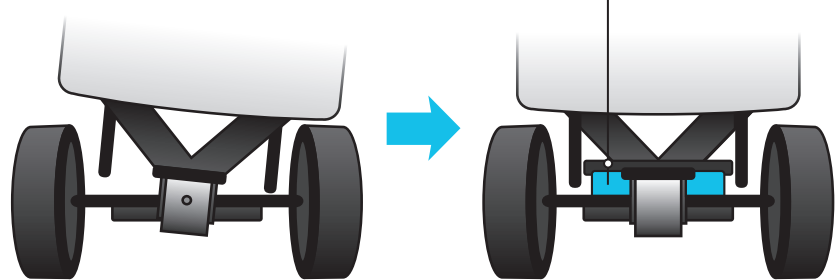

Safety Doesn't Have to be Complicated

Unlike the complex systems offered by some competitors, our cushioned stability control is simple, extremely effective and **zero maintenance** — enhanced lateral stability is achieved by a rubber damper placed between the axle and frame.

Seeing is Believing

Cylinders are positioned behind the mast rails resulting in fewer visual obstructions for the operator. Ideal for facilities that transport delicate loads, our optional OptiView® mast makes fork positioning and load handling easier.



OSHA strictly regulates carbon monoxide (CO) levels in the workplace for good reason.



The Nomad's CO levels are among the lowest in its engine class — three times lower than those of a major competitor based on 2015 certification results from the California Air Resources Board.

We achieved these lower and cleaner emission levels through the higher combustion efficiency delivered by our electronic engine control system that incorporates a Vehicle Control Module (VCM), Engine Control Module (ECM) and a 3-way catalytic muffler.

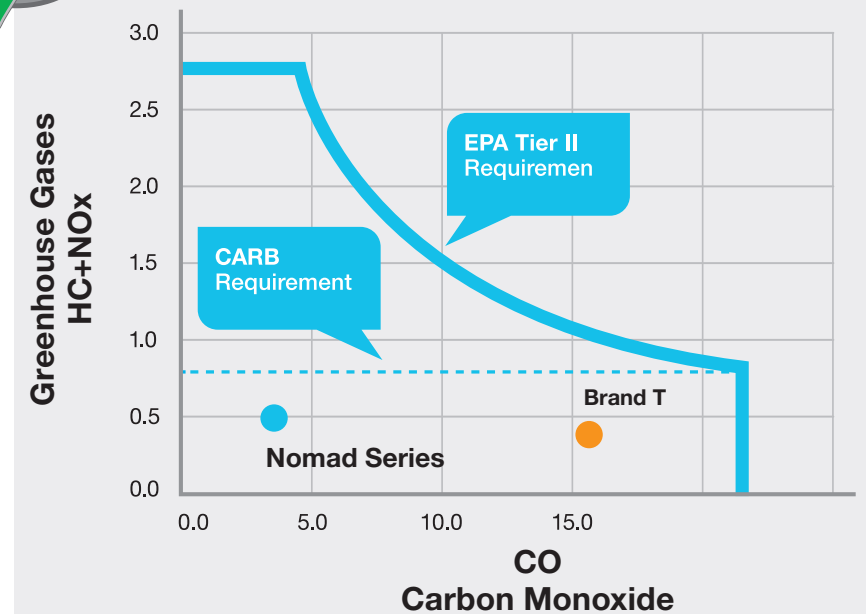

*Based on 2015 CARB certification results.

Control Freak

The Nomad offers a comprehensive array of features and options that not only allows you to control and manage machine functions, but also the speed, economy and performance of your entire operation.

Single Handle Control Lever

Faster, easier and more fluid, our single handle control combines both lift and tilt functions for greater productivity. It's standard equipment on the Platinum II Series — and not available from any other forklift brand. Separate control levers are available at no charge.



Auto-Tilt Leveling System

Press the button on the hydraulic control lever to tilt the forks forward to a horizontal position. This option is used for easier load placement and retrieval operations.



Parking Brake Alarm

As part of the Operator Presence System, a warning buzzer alerts the driver if he leaves the seat without first setting the parking brake.

Forward Thinking Back-Up Alarm

Our standard back-up alarm provides plenty of notice to pedestrians and other drivers in the area. For applications with varying noise levels, there is an optional self-adjusting alarm that adjusts sound volume based on ambient noise levels.

Make a Positive Impact

A variety of optional impact sensors are available to record each time the forklift comes into contact with a stationary object, allowing you to respond accordingly.



Find Your Top Travel Speed Easier



With an optional speed switch, drivers can toggle from a high speed pre-set in one area then select a low speed, confident they are adhering to corporate requirements*.



Select the security key switch option to lock in a pre-set high or low speed*.

Set Travel Speeds Without Losing Productivity

Top travel speed is electronically controlled, so you won't sacrifice lift performance. The great news? No tools are needed to set desired speeds*.

* Speed pre-sets performed by trained service technician

The Ultimate in Control

The interactive meter panel on the Platinum II Series provides operators and technicians with a wealth of information through its LCD warnings and readouts. A visual indicator for its return-to-neutral feature shows the forklift's transmission direction.

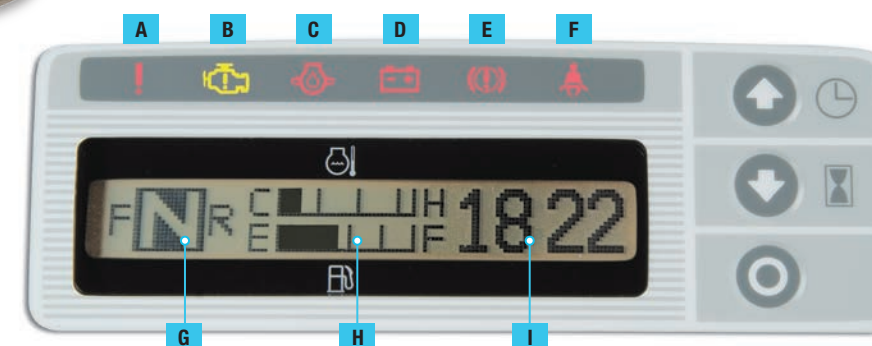

Our multi-function display provides an at-a-glance view of critical functions:

- A** Multipurpose warning
- B** Check engine warning
- C** Oil pressure warning
- D** Charge warning
- E** Parking brake warning
- F** Seatbelt warning
- G** Directional indicator
- H** Fuel & water temperature gauges
- I** Multi-function display:
 - Hour meter
 - Clock/calendar
 - Speedometer
 - Programmable service reminder
 - Error codes

Make It Yours

Unlike competitive brands, our forklifts come standard with the most essential and popular features and accessories. In addition, we offer a complete menu of additional options that allows you to customize your forklift to fit your specific workplace environment, operations and business objectives. On these pages, you'll find available options that are both innovative and economical — but it's only a portion of what we offer. So if you don't see what you're looking for here, call your UniCarriers dealer for more options.



• Strobe & Work Lights



• Air Intake Pre-Cleaner



• Overhead Guard-Mounted Fire Extinguisher



Blue LED Pedestrian Awareness Light

Reverse driving actuates an optional blue spotlight to illuminate the floor, for advanced visual warning.



Swivel Seat

Convenient release lever allows the seat to rotate 15° in either direction. Includes overhead guard mounted handle and horn button to simplify reverse driving.*



Fingertip Controls

Increase operator productivity with ergonomic hydraulic controls. Choose single joystick or multiple lever designs.*



Extended Overhead Guard

Extension provides protection to mounted components, including on-board computer and headlight (shown).

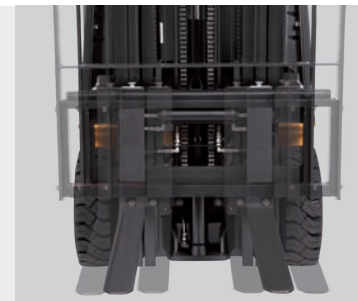

Sideshifting Fork Positioner

Hydraulically positions forks, eliminating the need for manual adjustment by the operator, providing increased productivity.



Debris Resistance Package

Includes a belly screen and slotted wheel well inserts to prevent larger debris from entering the engine compartment and affecting key components. For additional protection, select the Recycler Package.

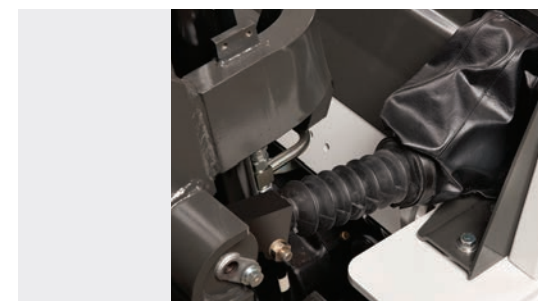

Tilt Cylinder Protection

Cylinder boots and covers provide extra protection against contaminants that can cause premature wear on cylinder packing.



Polycarbonate Overhead Guard Cover

Prevents small debris from falling through the overhead guard.



Swing-Down LP Bracket

Gas-spring assist automatically lowers and positions tank for faster, easier replacement.*

Option Availability

	Standard	Optional
	LP	DUAL FUEL
VEHICLE MANAGEMENT		
Vehicle Control Module (VCM)	●	●
Operator security PIN access	●	●
Interactive LCD meter panel	●	●
Engine coolant temperature gauge	●	●
Oil pressure, transmission fluid and low coolant warning lights	●	●
LPMax low fuel warning light	●	●
Fuel gauge - gas	—	●
SmoothShift System	○	○
Starter interlock - low LP	○	○
POWERTRAIN		
Electronic Engine Control System	●	●
Engine/transmission protection and warning system	●	●
Three-way catalytic converter	●	●
Cushioned stability control	●	●
Travel speed control (high/low speed selector)	○	○
Controlled acceleration (power/economy selector)	○	○
Radiator screen	○	○
Diffusion exhaust muffler	○	○
LP SYSTEM		
Swing-out LP bracket	●	●
Swing-down LP bracket*	○	○
BRAKE		
Parking brake with warning buzzer	●	●
Parking brake transmission interlock	●	●
MAST		
Seat actuated auto-mast lock system	●	●
OptiView® three-stage mast	○	○
High-Visibility Carriage	○	○
HYDRAULIC SYSTEM		
Single lift/tilt control lever	●	●
Separate lift & tilt control levers	○	○
Automatic fork leveling	○	○
OPERATOR CONVENIENCES		
Full suspension seat with weight & lumbar adjustment	●	●
OHG-mounted LED headlights	●	●
Rearview mirrors	○	○
Rear LED combination light package	○	○
Rear LED drive light	○	○
Secure rear grip with horn button	○	○
PROTECTION/SECURITY		
Operator Presence System with return-to-neutral and auto mast lock	●	●
Seatbelt interlocks	○	○
UL Safety rating*	○	○
Back-up warning alarm	●	●
Self-adjusting back up alarm	○	○
Fire Extinguisher	○	○

* Available only on 5000-lb. capacity model.

Specifications

SHORT MODEL CODES	AF30LP AF30DF	AF35LP AF35DF	AF50LP AF50DF
Engine Model	K21	K21	K21
Load Capacity - lb	3,000	3,500	5,000
Wheel Base - in	50.8	50.8	59.1
Overall Width - in	40.7	40.7	46.3
Overall Length (to face of forks) - in	83.9	85.0	92.9
Overall Height (OHG) - in	83.0	82.7	82.3
Turning Radius (outside) - in	72.6	73.8	80.7

*Optional feature available on the 5,000-lb. capacity model only.