

# UNI CARRIERS®

## □ FORKLIFT □

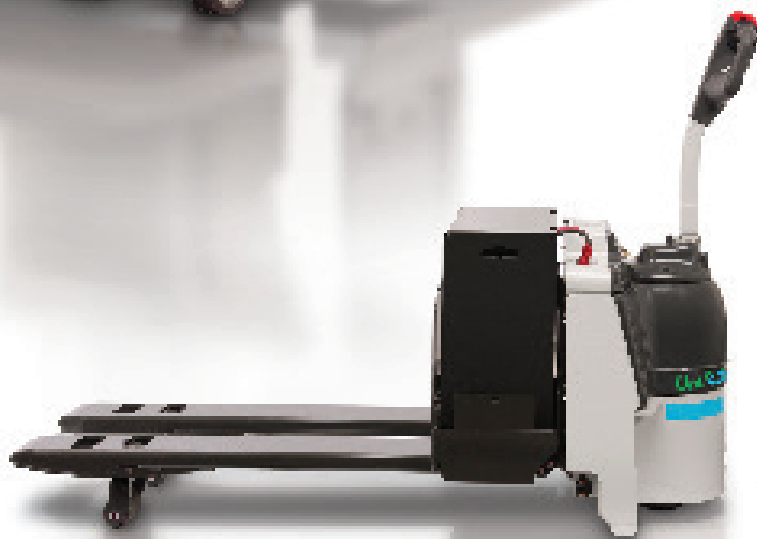

Walkie/Rider Pallet Trucks  
Walkie Pallet Trucks

24 Volt AC-Powered  
6,000 & 8,000 lbs. Capacities

RPX & WPX Series

# RPX & WPX Series Applications

Highly versatile, reliable and maneuverable, UniCarriers Platinum Series Pallet Trucks provide both rider and walkie options that deliver superior performance in a variety of applications, including:

- Manufacturing
- Warehousing
- Coolers / Freezers
- Multiple Operating Environments



Look for these symbols for features available only on UniCarriers pallet trucks or that provide a proven performance advantage as compared to competitive trucks.



# NEVER QUIT.

It defines our forklifts and the company that builds them.

Over the course of a century, the company known as UniCarriers took shape. As we grew and evolved into a US manufacturer with a global reach in nearly 100 countries worldwide, much has changed, but one thing hasn't: our mission. UniCarriers is committed to providing you with the ultimate in reliability, performance, and value.

And that commitment can be seen in UniCarriers Platinum Series Pallet Trucks. Engineered to offer unmatched reliability and performance, they move up and down crowded aisles, in and out of coolers and freezers and to and from the loading dock with amazing efficiency. In fact, no other pallet trucks are as well designed to withstand years of day-in and day-out operation, while delivering an exceptionally low cost of ownership. But that's only the beginning: superior maneuverability, maximum operator comfort, servicing ease, and rugged construction are all combined in our pallet trucks.



## Up Your UpTime

Discover reliability features that cut downtime and keep your business up and running



## Built To Last

These pallet trucks are engineered to excel in the harshest environments



## Control Freak

You're in complete control when it comes to managing costs and productivity



## Sweet Savings

The RPX and WPX are designed to deliver you a low cost of ownership year after year after year



## Make It Yours

Already well appointed, you can customize our pallet trucks to meet your specific needs



## WPX

We've built-in an unbeatable package of productivity features in this walkie pallet truck



To learn more, and a find a dealer near you, visit [UniCarriersAmericas.com](http://UniCarriersAmericas.com)



# Up Your UpTime

Your operation can't shut down or slow down because of the equipment you use. That's why our pallet trucks are designed to deliver maximum uptime. From the tips of the forks to the switches on the handle, our trucks are engineered to do more, withstand more, and deliver more, every day.

Unlike competitive equipment, our standard pallet trucks can operate in all environments, moving swiftly and reliably from coolers and freezers down to -20°F (-28.9°C) to dry ambient environments. The temperatures in your operation may vary, but the quality and reliability of our pallet trucks never do.

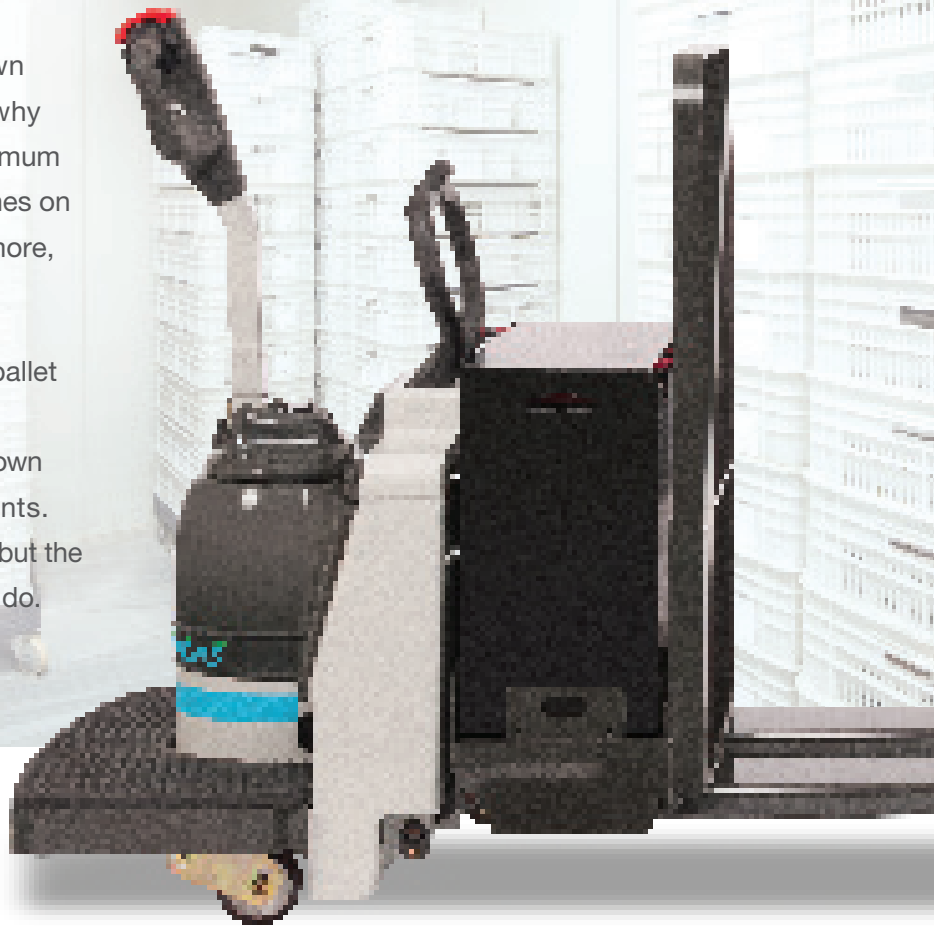

## Wet, Dry, Hot or Cold Our Sealed Systems Can Do it All



With the RPX, one truck *can* do it all — moving from coolers and freezers to dry ambient environments where condensation can occur. As a safeguard, all of our pallet trucks are equipped with **sealed switches, an epoxy coated control board, IP65 rated sealed controller, and sealed steer race** — all housed within our rugged frame that's protected by a durable powder coat paint finish. Add in our other features like AC motor control, thermal cut back and onboard self-diagnostics, and you have one very versatile machine.



To learn more, and find a dealer near you, visit [UniCarriersAmericas.com](http://UniCarriersAmericas.com)



### Our AC Motor Does More for Less

Greater torque and faster speeds are only the beginning of what our proven 5.2 HP brushless AC drive motor delivers. This 24 Volt system features **enhanced thermal capabilities** and delivers consistent power during normal battery discharge, while **using less energy per cycle**. The result? Consistent performance shift after shift, with longer run times between charging.

Since **easier maintenance is a key to greater reliability**, our high-performance AC Motor is mounted vertically for better heat dissipation and ease of service.



### Our Controller Area Network (CAN) System Is Simply Smarter

This innovative design allows digital communication between all operational controls on the steer handle to the truck's controller, allowing multiple signals to travel through the same wire. Plus, every minute the truck is on, it's self-monitoring to assure reliability.

Compare our design to that of our competitors. While competitive systems feature large, bulky connectors which house a web of complex wiring, our exclusive CAN System uses **just four wires** (data in/out and power in/out) in the controller head. The result? A greatly simplified system with enhanced dependability.



### Protection of Key Components

Unique steer race and enclosed frame design help keep major components protected — including drive motor, controller and hydraulic system — resulting in less maintenance and longer life.



### Simplified Maintenance Throughout

By making maintenance points more accessible, we cut the time and effort required to keep our machines and your operation moving. Consider this: **every grease fitting is accessible from the top side of the truck, so no lifting is necessary.**

You'll find common sense design features like this throughout our trucks — but not on our competitors.





# Built To Last

Packed trailers, extensive shuttle runs, heavy loads, long days. You have to be tough to work in that kind of environment, and UniCarriers Pallet Trucks are built to not only withstand these conditions, but thrive in them. It's not just the rugged steel construction, but the innovative designs throughout our trucks that shield both machine and man from abuse.

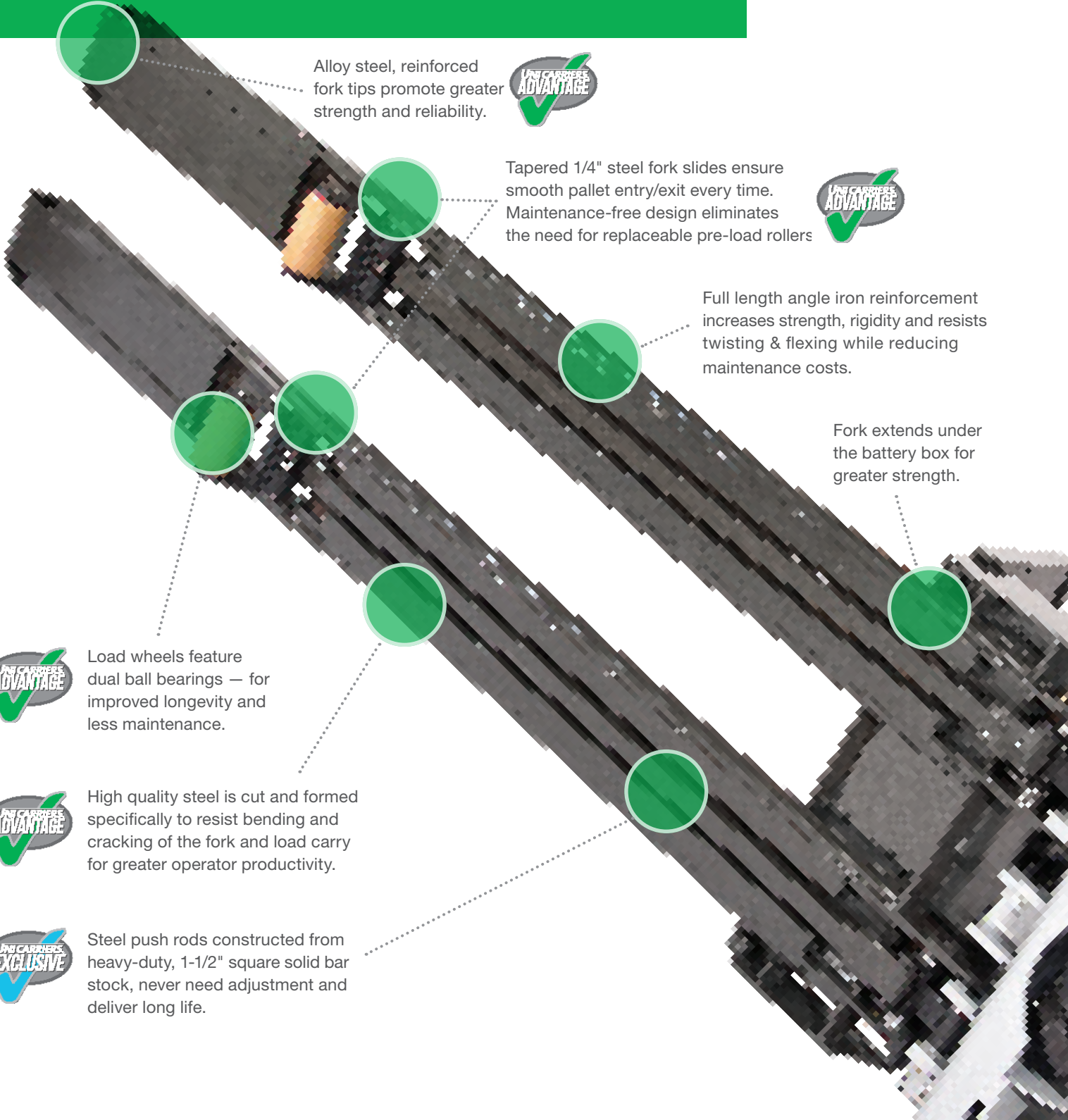

Alloy steel, reinforced fork tips promote greater strength and reliability.



Tapered 1/4" steel fork slides ensure smooth pallet entry/exit every time. Maintenance-free design eliminates the need for replaceable pre-load rollers



Full length angle iron reinforcement increases strength, rigidity and resists twisting & flexing while reducing maintenance costs.

Fork extends under the battery box for greater strength.



Load wheels feature dual ball bearings — for improved longevity and less maintenance.



High quality steel is cut and formed specifically to resist bending and cracking of the fork and load carry for greater operator productivity.



Steel push rods constructed from heavy-duty, 1-1/2" square solid bar stock, never need adjustment and deliver long life.

## Rise Above Costly Damage

Take control using the Auto-Lift feature to ensure **forks are automatically at their maximum lift height during operation**. Optional feature provides ample clearance over dock plates or uneven floors, reducing the chance of pallet damage or replacement of costly load carry components.

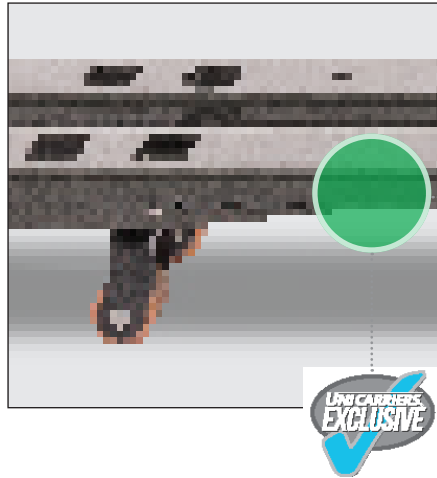

## Protects Your Truck, Protects Your Budget

With our push design lift linkage, the solid steel tie rods never extend beyond the plane of the fork, but move down the middle, **improving ground clearance, preventing possible damage, and reducing maintenance costs**. In competing systems, the tie rods extend beyond the forks, exposing them to costly damage, especially while driving over dock plates.



## No Bends, No Dents No Rust, No Problem

The hood and cover on our pallet trucks are made of rugged polycarbonate that won't bend, dent, fade or rust, while **the entire frame (including the load carry) is powder coated inside and out**, for even greater durability.

## Keeps Your Business Rolling

Heavy duty, yet simple caster design incorporates single-point height adjustment and an angled side bracket to prevent dock plate hang-ups. Accessible grease fittings on swivel and axle help promote routine maintenance.

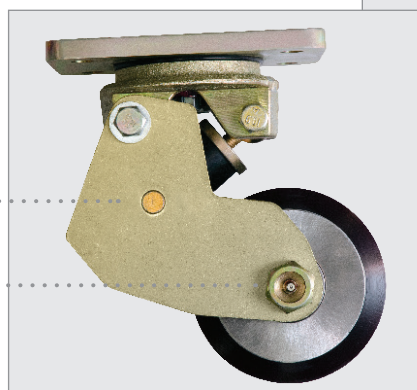
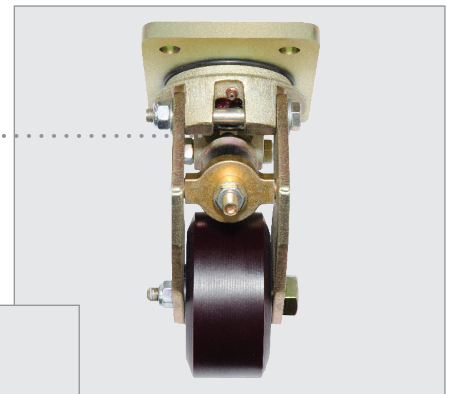

To learn more, and find a dealer near you, visit [UniCarriersAmericas.com](http://UniCarriersAmericas.com)



# Control Freak

Whether it's navigating tight aisles, handling heavy, uneven loads, picking multiple orders, or traveling to and from the dock, UniCarriers pallet trucks put you and your operators in control. From the ergonomic design of the steerhead to the size and comfort of the platform, our trucks have been engineered to put your operators in comfortable command of any situation.

Steel reinforced fiberglass-filled polymer construction offers high impact resistance



Maintenance-free electronic horn design eliminates rust due to condensation for longer economic life.



Large safety reversing button changes truck direction if contact is made.



Requiring significantly less effort versus twist grip controls, our **thumb-operated rotary controls** allow the operator to easily adjust travel and direction from either side of the truck.



Hall Effect speed and acceleration control **simplifies maintenance and limits downtime** due to its non-contact design that eliminates mechanical wiping action, potentiometers, and heaters.

Sealed switches require no heaters or thermostats, are designed for a minimum of 5,000,000 actuations, and can operate in coolers, freezers and wet rooms at temperatures as low as -20°F (-28.9°C).

Optional Sidetracker controls are strategically placed within easy reach for assured control of the truck when walking beside it — available with our Coast Control feature.





### Coast through Your Picking Operations

To improve picking efficiency, select our optional Coast Control with manual toggle lever. Optional sidetracker features include two side switches, conveniently located inside the handle, for more precise control and greater flexibility.



### A Turn for the Better

A 190° steering arc, ball-bearing mechanism, large steering control head and spring loaded handle all contribute to easy navigating in the tightest of spaces.

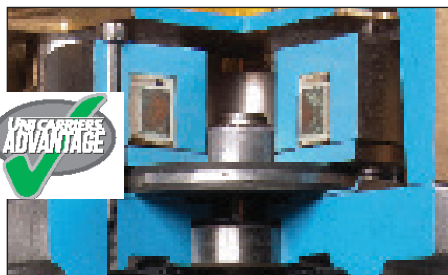

### Putting the Brakes on High Costs

Our Smart Electric Brake uses regenerative motor torque prior to brake actuation. It features fewer parts, never needs adjustment, and extends component life.



### Greater Operating Range

The spring-loaded handle and control head are ergonomically designed to maximize both operator control and comfort — delivering the ultimate in speed and maneuverability with minimum effort.



### Step Up to a Bigger, Better Platform

For greater comfort, productivity and safety, UniCarriers offers the largest operator platform in the industry. It features a bolt-on design for easy removal and replacement, a softer, anti-fatigue surface, and a rugged 1/2" formed plate steel outer bumper.



### Get a Grip on Comfort

Our ergonomically designed intermediate, high speed handrail is **rubber padded** for comfort but features thick tubular steel construction for years of service. The sealed, large, soft-touch buttons put your operator in complete control of fork raise/lower, high speed and horn functions. It's also **bolted onto the frame** for easy replacement or repair.



### A Multi-Function Display for a Multi-Faceted Truck

The standard Multi-function Digital Indicator includes a battery discharge indicator with lift interrupt, an hour meter gauge, and fault code display. For even greater control, add the optional Multi-function LCD Display (shown above) that features:

- **PIN Access:** Personal codes for up to 5 different operators
- **Performance Modes:** Custom settings to match driver capabilities and optimize productivity
- **On-Board Diagnostics:** Fast, easy troubleshooting and adjustment



To learn more, and find a dealer near you, visit [UniCarriersAmericas.com](http://UniCarriersAmericas.com)

# Sweet Savings

Everyone talks about Lowest of Cost of Ownership, but how do you judge it? We suggest you examine a pallet truck in four key areas: Reliability, Durability, Performance Features, and Operator Comfort/Productivity.

When you look at these essential elements of value, you'll see that our pallet trucks offer you the most complete package of time, effort and money-saving features available.

This value begins by offering you one truck for all environments and applications. Thanks to our unique design that includes sealed switches and logic boards, our pallet trucks can work in a wide range of operating environments, going from ambient temperatures to coolers, wet rooms, or freezers down to -20°F (-28.9°C).

But that's only the beginning.



# Check out all the RPX offers you...

## More uptime, all the time.

- Controller Area Network (CAN) System allows digital communication between the control handle and controller through only four wires for multiple signal transfers, greater reliability and easier maintenance
- Sealed switches are used for longer life, rated to a minimum 5,000,000 actuations, and require no heaters or thermostats
- Sealed controller has an IP65 rating and features thermal protection
- Push lift linkage does not extend beyond the plane of the fork helping to prevent damage
- Smart Electric Brake uses regenerative motor torque prior to brake actuation that extends brake life
- 5.2 HP heavy duty, three-phase brushless AC motor features enhanced thermal capabilities
- Hall Effect speed & direction control simplifies maintenance and limits downtime — no heaters or potentiometers, fewer moving parts
- Optional Auto-Lift helps prevent forks and linkages from being damaged in loading and unloading applications

## Durability down your aisles and down the road.

- Powder coat paint inside & out creates a scratch-resistant, durable finish
- Rugged polycarbonate hood and covers won't bend, dent or rust
- Heavy plate steel frame design is built to absorb and withstand impacts
- Operator platform features a rugged ½" steel outer bumper
- Fork assembly formed from ¼" plate steel
- Full-length angle iron reinforcement on forks increases strength, rigidity and assembly life, while resisting twisting and flexing
- Forks extend under the battery box for greater strength and rigidity

- Our unique push lift linkage features solid steel tie rods for exceptional strength and durability
- Steel reinforced steer handle is made of a special, virtually unbreakable fiberglass filled polymer
- Optional stainless steel axles and linkage pins deliver longer life and reduced maintenance
- Tubular steel construction adds greater durability to the intermediate, high speed hand rail

## Turning operator comfort into operating excellence.

- Advanced controller system offers smooth, infinitely variable speeds
- AC motor offers high speed/high torque performance
- Wide steerhead includes smart layout of large, soft-touch switches and push-button directional controls for greater operator comfort
- High speed hand rail reduces operator fatigue, improves grip and stability, and features low-effort switches
- Multi-Functional Digital Indicator features battery discharge, 3 hour meters
- Optional Coast Control is available with manual actuation to make order picking faster and easier
- Ergonomically actuated Sidetracker option enhances our Coast Control making it easier to control the truck while walking beside it
- Optional Tilt-Down Backrest makes battery removal faster and easier — 48", 60" and special sizes available
- Largest operator platform in the industry features an anti-fatigue platform mat
- Alloy steel fork slides facilitate pallet entry/exit and eliminate the need for pre-load rollers
- Steer handle's light, spring-loaded design makes it easier for operators to find their optimal operating position

- 190° steering range assures a tighter turning radius
- Reverse button is extra large for greater operator protection and automatically reverses truck travel if contact is made
- Thumb-operated rotary controls reduce the risk of repetitive motion injury and are gentler on wrists than twist grip controls
- Dual brake positions offer greater operator security

## Spend a lot less time and money on service.

- Rugged stability casters include a grease fitting and single point adjustment for reduced maintenance
- Easy hood removal means superior service access to controller, hydraulics, electric brake, drive system and motor
- Smart electric brake system requires no adjustments
- AC drive motor is vertically mounted for easy access and requires only 6 bolts to remove
- Sealed controller area keeps out dirt and debris
- The electric horn is maintenance-free and will never rust
- Optional LCD meter panel includes on-board diagnostics and troubleshooting
- Platform uses a bolt-on design for easy removal
- Drive wheel, load wheels and casters offer string guards to help prevent debris from getting caught in wheels
- Reinforced fork tip design uses no pre-load rollers and requires no maintenance
- Our unique push lift linkage never needs adjustment
- Hand rail is bolted to the frame for easy replacement or repair
- All grease fittings are accessible without raising the truck off the ground
- No heaters used mean fewer components to maintain



# Make It Yours

While the RPX features the industry's most comprehensive package of standard features, we know that your operation has its own unique set of challenges. That's why you can choose from an array of options to create a truly customized truck for your specific needs.



### Auto-Lift

This unique feature automatically raises forks to prevent dragging — a must for driving over dock plates or across sloped or uneven floors.



### Coast Control with Sidetracker

This reliable system makes order picking faster and control of the truck easier while walking.

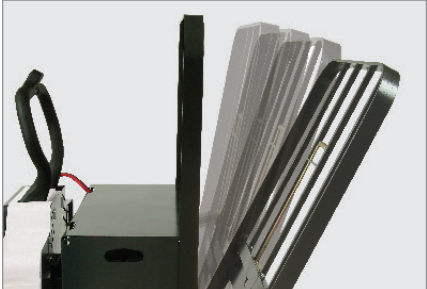

### Load Backrests

Slip-on and tilt-down designs are available to make battery removal quicker and simpler. Can also be welded on.

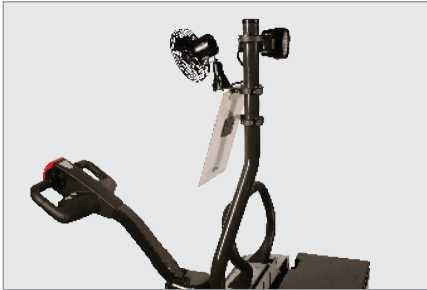

### Accessory Pole

Provides a convenient solution to securely attach options including work and strobe lights, operator fan and clipboard.

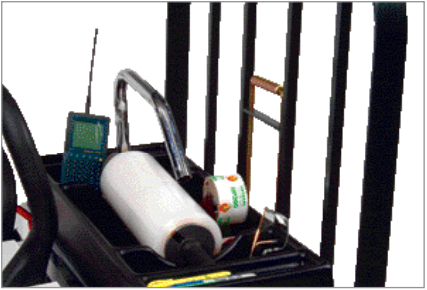

### Magnetic Convenience Tray

Handy tray adheres to the top of the battery box and includes a stretch wrap holder and room for tools.



### Selection of Drive Tires & Load Wheels

Choose from a variety of options to support your application.

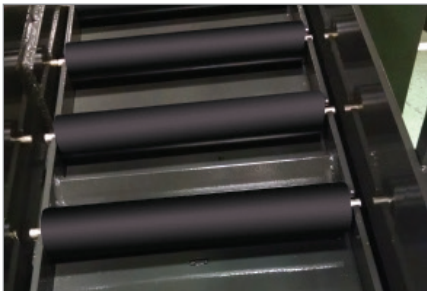

### Rust Free Battery Rollers

Roller design made of durable poly material incorporates an anodized metal pin for longer life.



### Extended Skirt

This important option provides additional protection for operators' heels. Not recommended for applications where dock plates are present.



### Multi-Function LCD

Includes on-board diagnostics, trouble shooting, selectable performance settings and more.

### Fuel Cell Ready

UniCarriers Pallet Trucks can be powered using fuel cell batteries. Contact your battery representative for information on fuel cell technology.



To learn more, and find a dealer near you, visit [UniCarriersAmericas.com](http://UniCarriersAmericas.com)





# WPX Walkie Pallet Truck



## When You Don't Need a Ride, the WPX Walkie Pallet Truck Gives You a Lift.

The WPX offers a durable, dependable, and versatile design for a wide range of applications in all kinds of operating environments. From manufacturing to warehousing to grocery, it's the one walkie pallet truck you can count on.

The WPX shares all the performance features of the RPX, including:

- 5.2 HP heavy-duty, three-phase brushless AC drive motor with enhanced thermal capabilities and greater torque
- Sealed switches and logic boards for operation in coolers, wet rooms, and freezers down to -20°F (-28.9°C)
- Controller Area Network (CAN) system uses just four wires to send multiple signals between the control handle and controller
- Rugged construction, including tubular steel steer handle
- Ergonomic features, including large, soft-touch switches
- String guards on all wheels
- Wide array of optional equipment, including Auto-Lift and multi-function LCD meter panel

 To learn more, and find a dealer near you, visit [UniCarriersAmericas.com](http://UniCarriersAmericas.com)

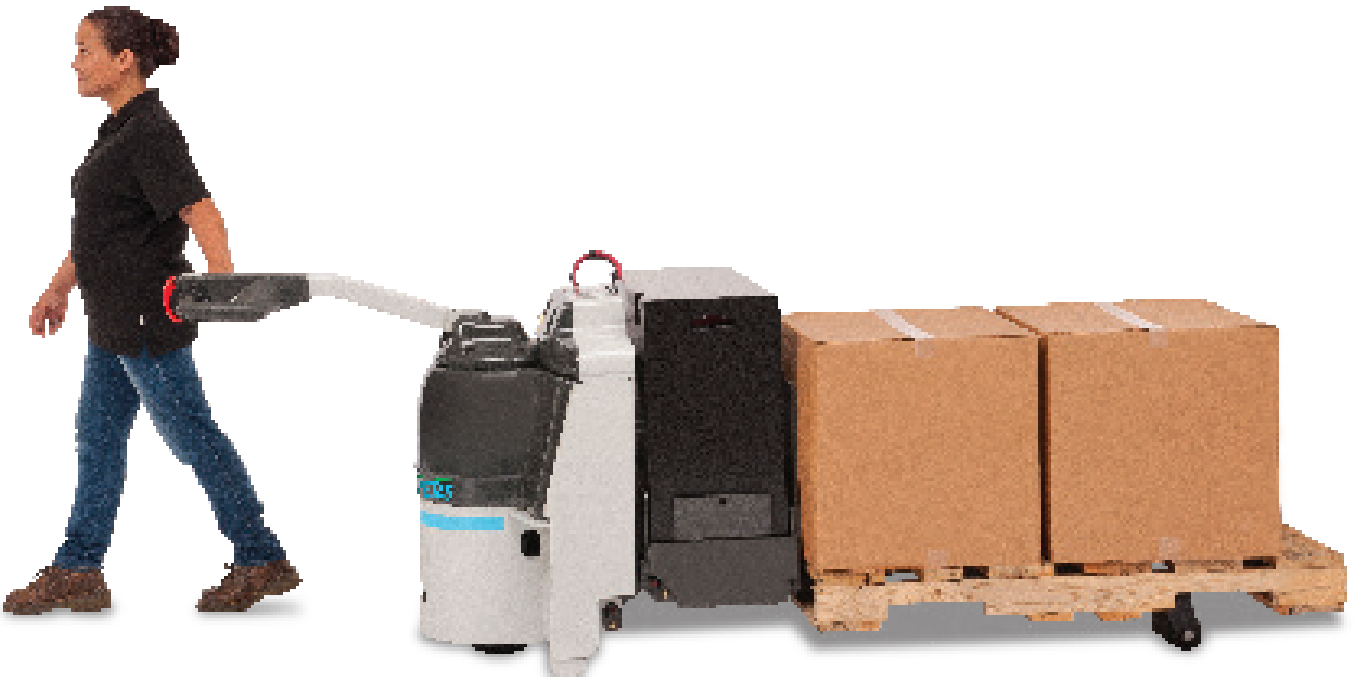



# Reliability.

It's the defining trait of our company and our forklifts.



UniCarriers' roots extend back over 100 years, and over that time, strong, reliable performance has always been the hallmark of our organization, our people and our equipment.

Today, our unrivaled reliability continues to provide UniCarriers' customers with a competitive edge. And together, we move the merchandise that moves world commerce with greater efficiency, economy and reliability.

When it comes to providing forklifts that make a difference for our customers and theirs...

## We Never Quit.

Forklifts of Michigan  
[www.forkliftsmi.com](http://www.forkliftsmi.com)  
616-455-2376

**UNICARRIERS**<sup>®</sup>  
**FORKLIFT**  
UniCarriersAmericas.com



SB-RPX/WPX 07-2015 Printed in U.S.A.

UniCarriers<sup>®</sup> is a registered trademark of UniCarriers Corporation. UniCarriers Americas Corporation reserves the right to make product changes relating to colors, equipment, specifications or available options without notice. For more information, contact your UniCarriers representative.